

# Hybrid Quantum Systems for Quantum Battery Design and Simulation

Alexandra Barbosa Gonzalez and William Munro

Quantum Engineering and Design Unit, OIST Graduate University, Okinawa, Japan  
alexandra.barbosa@oist.jp



## Motivation: Energy Storage in the Quantum Regime

- ▶ Quantum batteries (QBs) are quantum systems that leverage quantum effects, such as coherent cooperative interactions, to serve as temporary energy storage systems.
  - ▷ Most theoretical models assume **closed systems**.
  - ▷ Superextensive power scaling from collective charging leads to a **power enhancement** of  $\sqrt{N}$  compared to parallel charging in closed models [1].
  - ▷ Realistic quantum platforms are inherently **open and hybrid** involving decoherence and dissipation effects.
  - ▷ Theoretical protocols for QBs have the potential to be implemented using **hybrid quantum systems** (HQSs).
- ▶ **Goal:** To determine whether collective charging advantages predicted in ideal QB models persist in HQS based OQB models.

## QB models: Closed and Open

Aspect	Closed QB	OQB
Dynamics	Unitary evolution. Liouville von Neumann equation	Dissipative + unitary evolution. Markovian quantum master equation
Environment	Neglected	Explicit coupling to baths or loss channels
Energy storage	Ideally reversible	Limited by decoherence and leakage
Realization	Idealized	Platform-relevant (cavity QED, spins, etc.)
Goal	Fundamental bounds and advantage	Realistic protocols and optimization

## Idealized Collective Dissipative Charging

We reproduced the results from Quach and Munro (2020) [2].

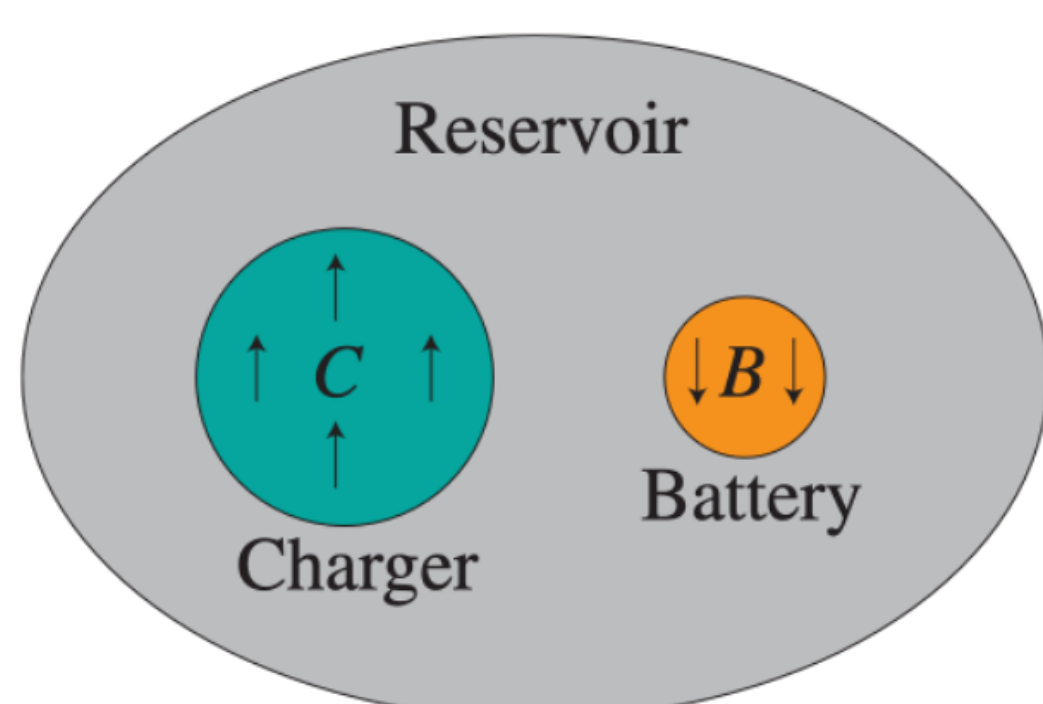

Figure 1: The charger and battery are modeled as two ensembles of 1/2 spins coupled to a common thermal reservoir, with the assumption that  $N_C > N_B$ . Adapted from Ref. [2].

Under the Born-Markov approximation:

$$\dot{\rho}(t) = -i \frac{\omega}{\hbar} [J_C^z + J_B^z, \rho(t)] + \frac{\gamma}{\hbar^2} [(\bar{n} + 1) \mathcal{L}(J_C^- + J_B^-) + \bar{n} \mathcal{L}(J_C^+ + J_B^+)] \quad (1)$$

- ▶ Dark state stabilization.
- ▶ Collective engineered dissipator ( $J_C^- + J_B^-$ ).
- ▶ Power density scales with  $N_B$ .
- ▶ Energy density with  $i = B, C$ , and battery power density:

$$E_i(t) = \omega \left( \frac{\langle J_i^z(t) \rangle}{N_i} + 0.5 \right), \quad P_B(t) = \frac{dE_B(t)}{dt}$$

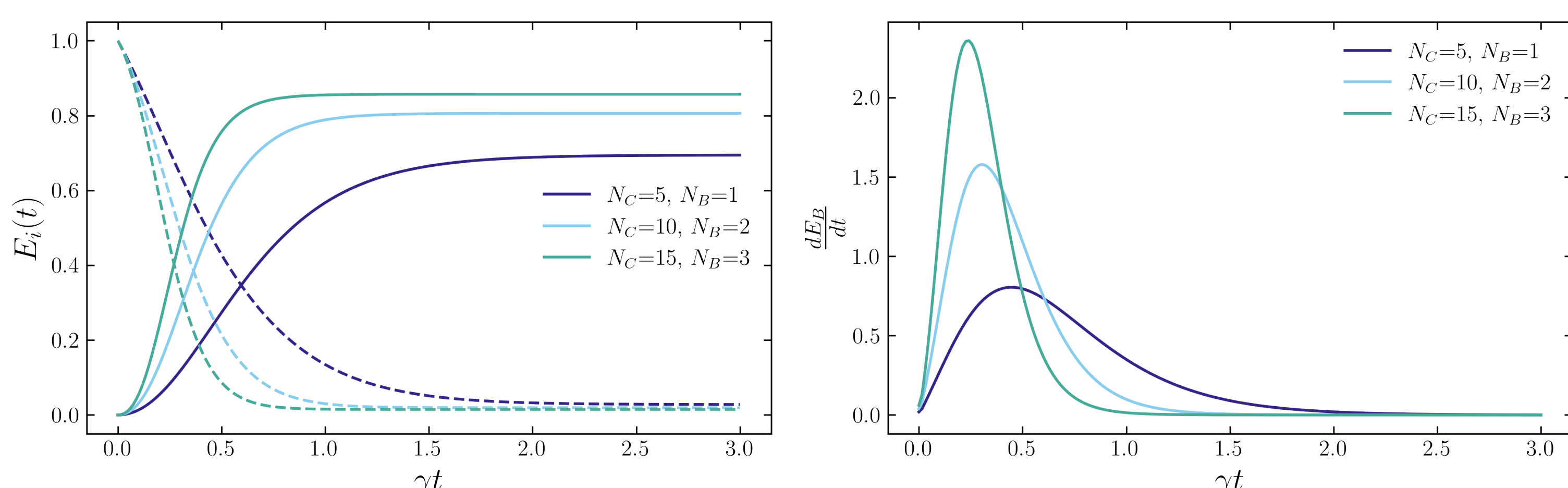

Figure 2: (Left) Energy density of the charger  $E_C(t)$  (dotted) and the battery  $E_B(t)$  (solid). (Right) The power density of the battery  $P_B(t)$ .

## Spin-Cavity QB model

- ▶ Introduced a single cavity mode with cavity loss rate  $\kappa$ .
- ▶ The cavity interacts with the ensembles with a coupling strength  $g$ .
- ▶ Dissipation is described by photon leakage from the cavity through the cavity annihilation operator  $a$ .

$$H = \frac{\hbar\omega}{2} (J_C^z + J_B^z) + \hbar g (a^\dagger (J_C^- + J_B^-) + a (J_C^+ + J_B^+)) + \hbar\omega_c a^\dagger a. \quad (2)$$

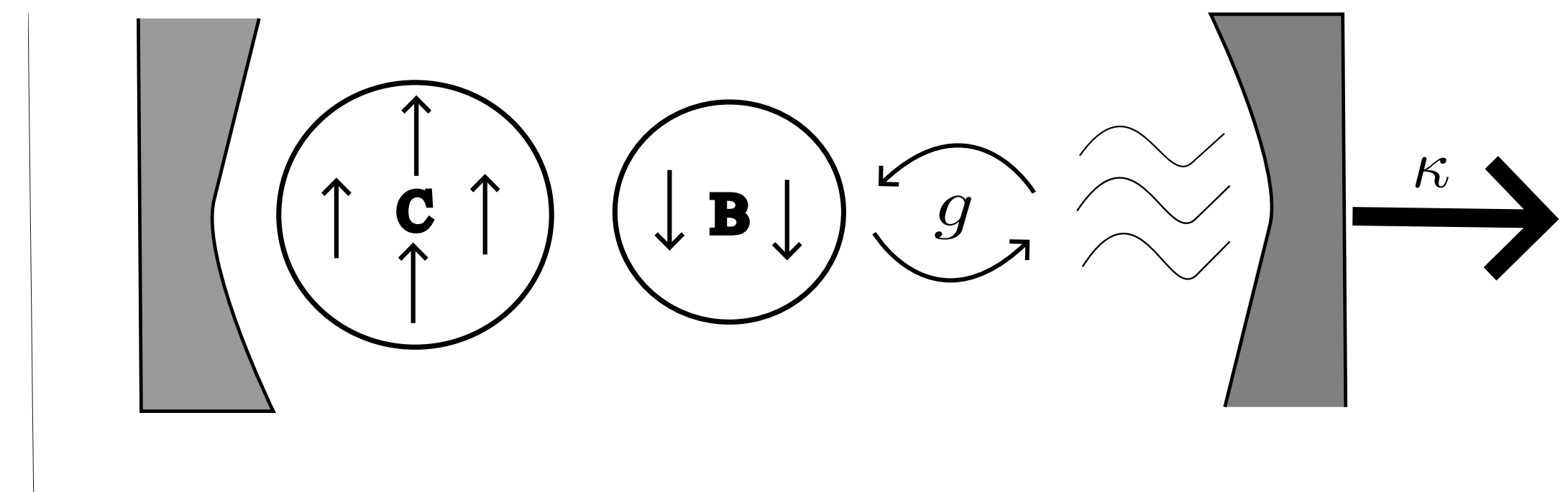

Figure 3: The charger and battery are modeled as two ensembles of 1/2 spins coupled to a cavity mode with the assumption that  $N_C > N_B$ .

$$\dot{\rho}(t) = \frac{-i}{\hbar} [H, \rho(t)] + \frac{\kappa}{2} (2a\rho a^\dagger - a^\dagger a \rho - \rho a^\dagger a). \quad (3)$$

- ▶ Ratio  $g/\kappa$  controls the dynamics ranging from coherent like to perfectly dissipative dynamics.
- ▶ In the fast cavity limit ( $\kappa \gg g$ ) the cavity is adiabatically eliminated and  $\gamma = 4g^2/\kappa$ .

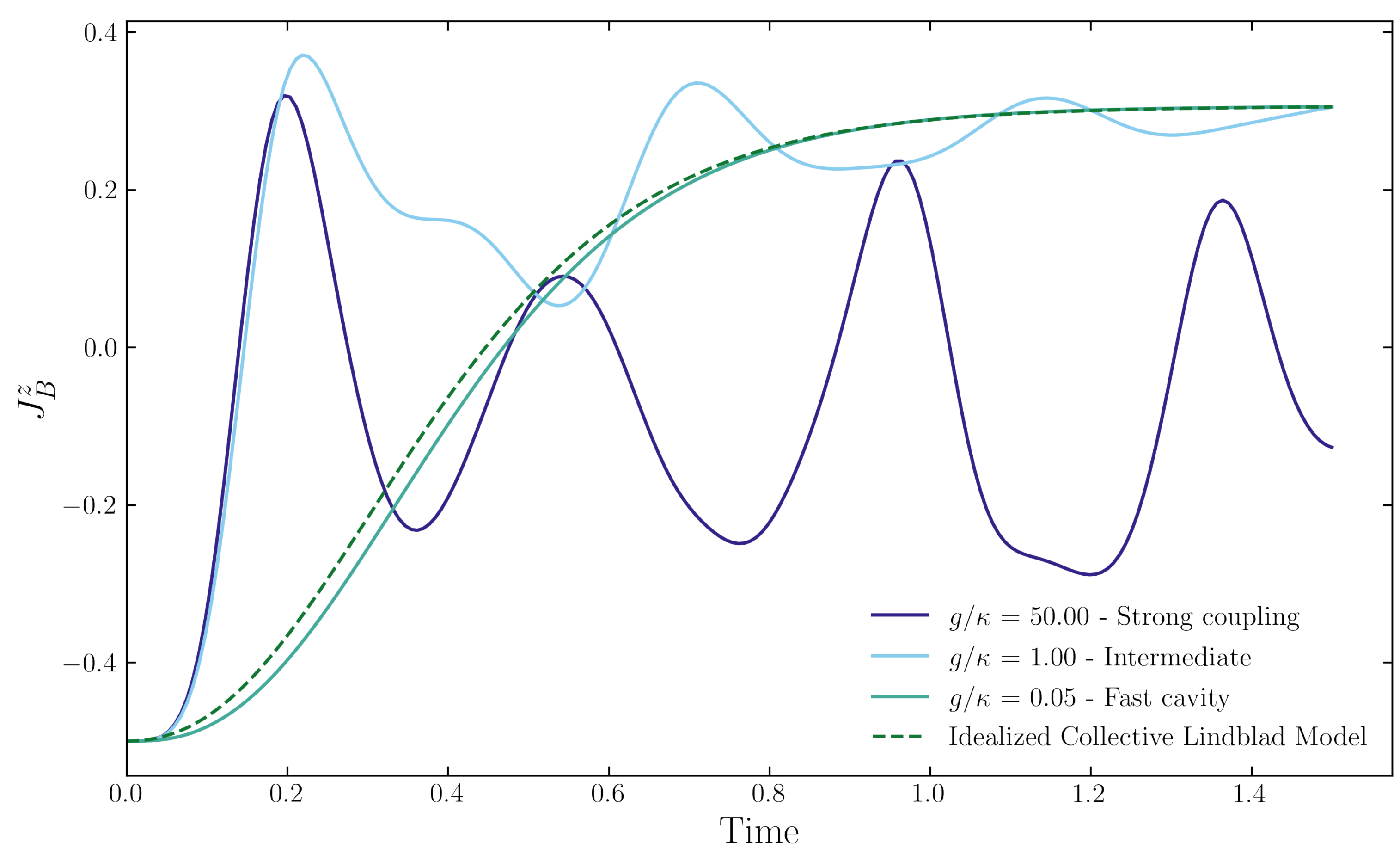

Figure 4: Numerical results for  $J_B^z$  for system size  $N_C = 10$ ,  $N_B = 2$  in the strong coupling regime ( $g \gg \kappa$ ), intermediate regime ( $\kappa \sim g$ ) and fast cavity regime ( $\kappa \gg g$ ) compared to the baseline idealized model with  $\gamma = 1$ .

## Research Plan

1. Analysis of scalability and dissipation in the collective Spin-Cavity OQB model.
2. Effects of **non-Markovian** environments.
3. Optimization of charging, stabilization, and discharging protocols in realistic experimental platforms.

## Expected Outcomes

- ▶ Establish **quantitative bounds** on scalability under realistic conditions.
- ▶ Study trade-offs between collective enhancement and stability.
- ▶ Assess the feasibility of implementing QBs in practical quantum technologies.

[1] F. Campaioli et al., Phys. Rev. Lett. 118, 150601 (2017)

[2] J. Q. Quach and W. J. Munro, Phys. Rev. Applied 14, 024092 (2020)